

Planar® T* f/1.2 – 85 mm

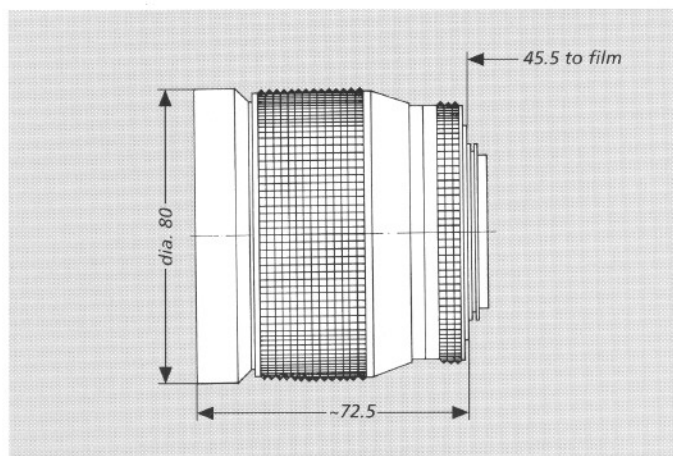

CONTAX®/YASHICA® mount

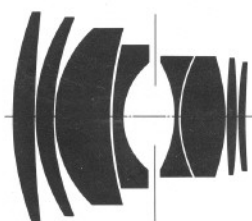

Both its initial aperture and image quality put the 85 mm Carl Zeiss Planar® T* f/1.2 lens in a class of its own. Compared with the 85 mm Planar® T* f/1.4 lens, the possibility of increasing the aperture to f/1.2 provides the photographer with 40% more light when needed. At full aperture, the reduction in

depth of field can be used in portrait photography for picture composition. In available light photography, this means that the existing light can be better utilized, and in sports photography faster shutter speeds can be chosen.

Another major advantage of this lens is its "floating element" which ensures that the high image quality is retained in close-ups.

Cat. No. of lens:	102163	Weight:	approx. 874 g
Number of elements:	8	Focusing range:	∞ to 1 m
Number of groups:	7	Aberration correction for close range by floating element	
Max. aperture*:	f/1.2	Entrance pupil*:	
Focal length*:	83 mm	Position:	71.4 mm behind the first lens vertex
Negative size:	24 x 36 mm	Diameter:	66.5 mm
Angular field 2w*:	29° diagonal	Exit pupil*:	
Mount:	focusing mount with bayonet; TTL metering either at full aperture or in stopped-down position. Aperture priority/Shutter priority/ Automatic programs (Multi-Mode Operation)	Position:	29.9 mm in front of the last lens vertex
Aperture scale:	1.2 – 2 – 2.8 – 4 – 5.6 – 8 – 11 – 16	Diameter:	59.5 mm
Filter connection:	clip-on filter, diameter 80 mm screw-in type, thread M 77 x 0.75	Position of principal planes*:	
		H:	53.3 mm behind the first lens vertex
		H':	44.8 mm in front of the last lens vertex
		Back focal distance*:	38.2 mm
		Distance between first and last lens vertex:	75.7 mm

* at ∞



Performance data: Planar® T* f/1.2 – 85 mm No. 102163

1. MTF Diagrams

The image height u – calculated from the image center – is entered in mm on the horizontal axis of the graph. The modulation transfer T (MTF = Modulation Transfer Factor) is entered on the vertical axis. Parameters of the graph are the spatial frequencies R in cycles (line pairs) per mm given at the top of this page.

The lowest spatial frequency corresponds to the upper pair of curves, the highest spatial frequency to the lower pair. Above each graph, the f -number k is given for which the measurement was made. "White" light means that the measurement was made with a subject illumination having the approximate spectral distribution of daylight.

Unless otherwise indicated, the performance data refer to large object distances, for which normal photographic lenses are primarily used.

2. Relative illuminance

In this diagram the horizontal axis gives the image height u in mm and the vertical axis the relative illuminance E , both for full aperture and a moderately stopped-down lens. The values for E are determined taking into account vignetting and natural light decrease.

Modulation transfer T as a function of image height u . Slit orientation: tangential ——— sagittal - - - -
White light. Spatial frequencies $R = 10, 20$ and 40 cycles/mm

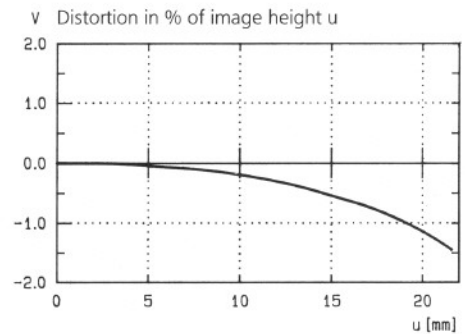
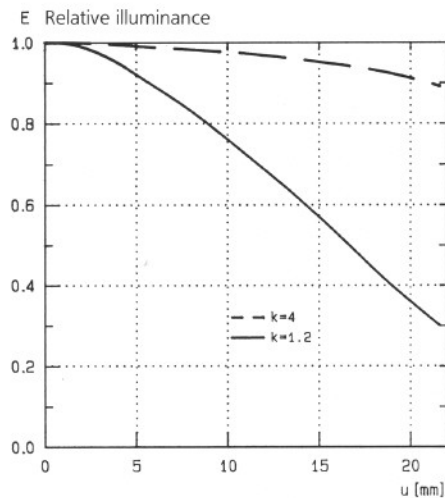
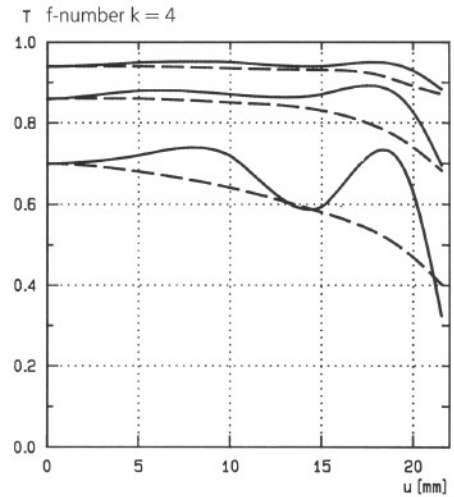
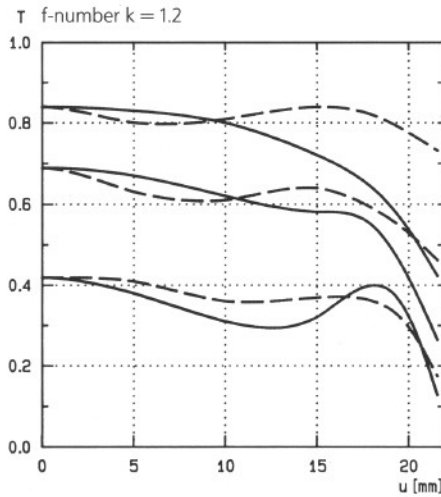

3. Distortion

Here again the image height u is entered on the horizontal axis in mm. The vertical axis gives the distortion V in % of the relevant image height. A positive value for V means that the actual image point is further from the image center than with perfectly distortion-free imaging (pincushion distortion); a negative V indicates barrel distortion.

Carl Zeiss

Photoobjektive
D-73446 Oberkochen
Tel.: (0 73 64) 20-61 75
Fax: (0 73 64) 20 40 45

For advice, please contact

ZEISS