

# MICROSCOPY

## C-DIC – a new microscopy method for rational study of phase structures in incident light arrangement

**031** Rainer Danz and Peter Gretscher,  
Carl Zeiss, Goettingen

Circular polarized light – Differential Interference Contrast (C-DIC) is a new polarization-optical differential interference contrast method where, unlike conventional DIC according to *Nomarski*, the DIC prism is arranged in circular, not linear, polarized light. Consequently, the interference contrast generated is invariant in relation to the oscillation orientation of the DIC prism, and so the latter can be rotated directionally in accordance with the characteristics of the object. This means that the stage does not need to be rotated, while the relationship with the object is preserved. For the user, this means more information and an increase in sample throughput.

### 1 Introduction: the basic principles of the DIC method

Differential interference contrast (DIC) according to *Nomarski* is currently the most popular interference microscopy method for high-contrast depiction of geometric and physical phase objects (differences in height/difference in phase shifts of adjacent structures: **Figure 1**).

The *Nomarski* method uses a modified Wollaston prism (**Figure 2**), which affects an angular split of the incident linear polarized light beams. This means that completely identical twin images of every object structure are produced, as in **Figure 3** and **Figure 4**, which, laterally offset by a small (“differential”) amount  $s \ll \text{object field}$ , interfere with one another.

The standardized light generation  $u(x')$  (or rather the standardized amplitude of the electrical or magnetic field vector) in the intermediate image plane is described by

$$u(x') = e^{-i\phi(x')} + e^{-i[\psi + \phi(x' - s)]} \quad (\text{Equation 1})$$

where  $\phi$  represents the relative object phase difference,  $x'$  the location coordinates in the direction of the image split,  $s$  the size of the image split (“shear”) and  $\psi$  the phase difference between the object wave and the laterally displaced reference wave. The phase difference  $\psi$  can be altered continuously by moving the Wollaston prism perpendicular to the optical axis.

By multiplying equation 1 by the complex conjugate function, the intensity distribution in the intermediate image plane is obtained, in accordance with  $I = uu^*$

$$I(x') = 1 + \cos[\phi(x') - \phi(x' - s) - \psi] \quad (\text{Equation 2a}).$$

If  $\psi = \pi/2$  and small  $\phi \ll \pi$ , equation 2a can be simplified as follows without loss of generality:

$$I(x') = 1 + \phi(x') - \phi(x' - s),$$

or

$$I(x') = 1 + s \frac{d\phi(x')}{dx'} \quad (\text{Equation 2b}).$$

In accordance with equation 2b, the intensity in the intermediate image plane is proportional to the first derivation of  $\phi(x')$  after  $x'$ , i.e. to the change in the relative phase difference of the image and twin image in the direction of the image split (**Figure 3b** and **4b**). This creates the impression of the image in relief that is characteristic of the DIC method (**Figure 3a** and **4a**). It is also evident that the relief contrast is not rotationally symmetric, for example in phase contrast or dark field. Maximum contrast is only to be expected in a preferential direction, in other words at phase boundaries that lie perpendicular to the direction of the split  $x'$  (orientation effect). When the direction of the split is determined, straight structures are therefore selected that are preferentially contrasted. Line structures that lie in the direction of the split (**Figure 5**, first and last images of the bottom row) are not contrasted or only partially contrasted, while phase structures arranged orthogonally can only be depicted simultaneously if they are diagonal to the image split (**Figure 5**, middle image of the bottom row). On the other hand, circular objects can be depicted in high contrast whatever the direction of the split, though the nature of the image varies (**Figure 5**, top row).

## 2 The limitations of the conventional DIC setup according to Nomarski

In materials microscopy, both circular and straight phase objects occur, which means that the sample and the direction of the split have to be rotated relative to one another to avoid misinterpretations due to the orientation effect. Naturally, it makes sense to rotate the direction of the split only, while keeping the object fixed, because otherwise highly precise and expensive rotary stages would have to be used; in addition, the relationship between the object, the orientation and the overall image of the sample examined would be lost if the object were rotated. Moreover, linear scanning stages are prescribed for a large number of applications, such as in microelectronics and micro-systems engineering. However, the DIC prism according to *Nomarski* cannot be rotated directionally because it only allows for the effective black/white or gray contrast in defined fixed positions relative to the polarizer and analyzer, as illustrated in **Figure 6**. The polarizer and analyzer have to be in the extinction position  $\alpha_{An} = \pi/2$ . In this case, the output intensity  $I_A$  is observed behind the analyzer, according to *Fresnel*, if there is no phase object in the object plane:

$$I_A = f(\alpha_{DP}, \psi) = I_E \sin^2 2\alpha_{DP} \sin^2 \frac{1}{2}\psi \quad (\text{Equation 3}).$$

This therefore means that maximum intensities or equal amplitudes of interfering component waves are only to be expected if the DIC prism is arranged diagonal to the polarizer and analyzer, i.e. if its oscillation orientation is  $\alpha_{DP} = (2n+1)\pi/4$ . This happens precisely four times, at  $45^\circ$ ,  $135^\circ$ ,  $225^\circ$  and  $315^\circ$ . In every other orientation, the intensity is reduced, or even disappears for  $\alpha_{DP} = n\pi/2$  ( $n = 0, 1, 2, 3, \dots$ ). Therefore, an (isotropic) phase object in the "prohibited" orientation positions of the DIC prism can hardly be depicted or cannot be depicted at all.

## 3 C-DIC: differential interference contrast in circular polarized light

What, then, should be done in order to be able to depict all straight object structures with maximum contrast using a fixed stage? The C-DIC method offers an elegant solution. Using the approach described below, the oscillation directionality of the DIC prism can be continuously varied without any loss of contrast:

in each of the illumination beam path and the image beam path, a quarter-wave plate (VWP<sub>1</sub> or VWP<sub>2</sub>) is arranged in such a way that the oscillation azimuths of the two plates form the angles  $\alpha_1$  and  $\alpha_2$  (**Figure 7** and **8**).

The formula for the output intensity  $I'_A$ , where there is no object, is complicated at first compared to equation 3:

$$I'_A = I_E \{ [\cos \frac{1}{2}\delta_2 \cos \frac{1}{2}\psi \cos \frac{1}{2}\delta_1 \cos \alpha_{An} - \cos \frac{1}{2}\delta_2 \sin \frac{1}{2}\psi \sin \frac{1}{2}\delta_1 \cos (\alpha_{An} - 2\alpha_{DP} + 2\alpha_1) - \cos \frac{1}{2}\psi \sin \frac{1}{2}\delta_2 \sin \frac{1}{2}\delta_1 \cos (\alpha_{An} - 2\alpha_2 + 2\alpha_1) - \cos \frac{1}{2}\delta_1 \sin \frac{1}{2}\delta_2 \sin \frac{1}{2}\psi \cos (\alpha_{An} - 2\alpha_2 + 2\alpha_{DP})]^2 + [\cos \frac{1}{2}\delta_2 \cos \frac{1}{2}\psi \sin \frac{1}{2}\delta_1 \cos (\alpha_{An} - 2\alpha_1) + \cos \frac{1}{2}\delta_2 \cos \frac{1}{2}\delta_1 \sin \frac{1}{2}\psi \cos (\alpha_{An} - 2\alpha_{DP}) + \cos \frac{1}{2}\psi \cos \frac{1}{2}\delta_1 \sin \frac{1}{2}\delta_2 \cos (\alpha_{An} - 2\alpha_2) - \sin \frac{1}{2}\delta_2 \sin \frac{1}{2}\psi \sin \frac{1}{2}\delta_1 \cos (\alpha_{An} - 2\alpha_2 + 2\alpha_{DP} - 2\alpha_1)]^2 \} \quad (\text{Equation 4}),$$

However, it becomes much simpler once the conditions for the two quarter-wave plates are inserted  $\alpha_1 = -\alpha_2 = \frac{1}{4}\pi$  (orientation of the quarter-wave plates diagonal to the polars) and

$$\delta_1 = \delta_2 = \frac{1}{2}\pi \text{ (the phase difference generated by a quarter-wave plate)}$$

$$I_A = I_E (\sin^2 \frac{1}{2} \psi + \cos^2 \alpha_{An} \cos \psi + \frac{1}{2} \sin \psi \sin 2\alpha_{An} \cos 2\alpha_{DP}) \quad \text{(Equation 5)}$$

and is finally simplified with crossed polars, i.e.  $\alpha_{An} = \frac{1}{2}\pi$ , to

$$I_A = f(\psi) = I_E \sin^2 \frac{1}{2} \psi \quad \text{(Equation 6)}$$

The intensity is now simply a function of  $\psi$ , no longer of  $\alpha_{DP}$ .

The conditions are then in place for the successive detection and maximum contrast of differently aligned phase structures through rotation of the DIC prism (Figure 5).

#### 4 Microscopy practice and examples of applications

The C-DIC method was launched on the market in the fall of 2002 in a number of Zeiss microscopes. It is extremely simple to use with these microscopes: circular polarized light is generated and analyzed by a reflector module (**Figure 9b**), which is precisely the same size as the polarizer/analyzer reflector for conventional DIC and can therefore be placed in the same position.

The DIC prism for C-DIC is installed in a special slider (**Figure 9a**) which can be used for reproducible azimuthal rotation in order to create high-contrast images of differently aligned phase structures. The phase difference  $\psi$  can also be adjusted for gray contrast variation by moving the prism perpendicular to the optical axis.

The first test objects used were  $MgF_2$  steps on a glass substrate (**Figure 10**) and phase steps arranged orthogonally on a front surface mirror (**Figure 11**).

For the depiction of the  $MgF_2$  steps, where the directions of the split are perpendicular to one another, the huge difference in information is obvious. Figure 11 clearly demonstrates that the vertical structures are more likely to be depicted where the direction of the split is E-W (left image), both the vertical and the horizontal structures are depicted where the direction is SE-NW (middle image), while, finally, the horizontal structures are more likely to be depicted where the direction of the split is S-N. However, the three images also show that structures with an alignment that does not coincide with any of the three directions chosen are always contrasted (pair of parallel structures SSE-NNW).

**Figure 12** presents an optical surface that has been marked using an excimer laser. The quality of the ablation points can be assessed superbly using C-DIC because every single piece of information about the object can be gathered due to the continuous change in the direction of the split. This is absolutely impossible with conventional DIC because the special shape of the object examined means that a rotary stage cannot be used.

#### 5 Summary

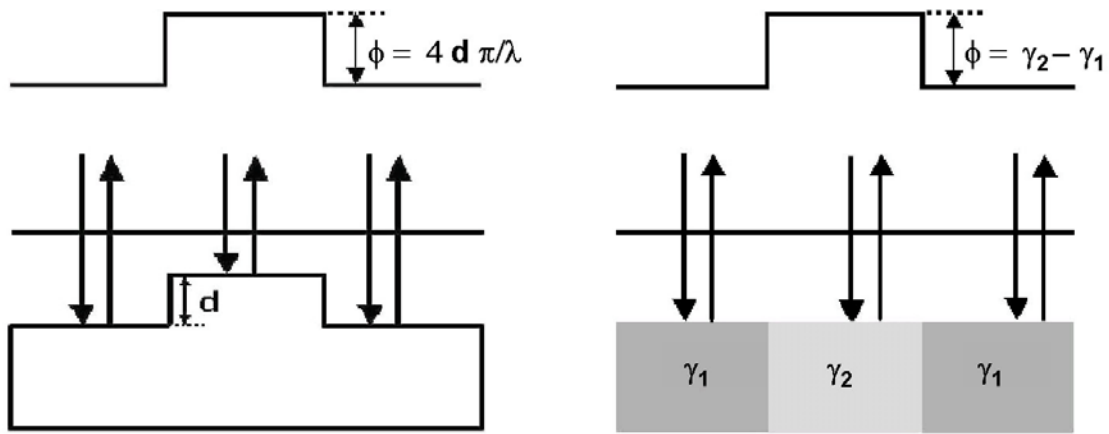
By using circular polarized light and suitably designed (rotating and sliding) C-DIC prisms it is possible to depict phase structures in incident light with high resolution and high contrast, regardless of their alignment, without having to rotate the object itself.

#### Literary references:

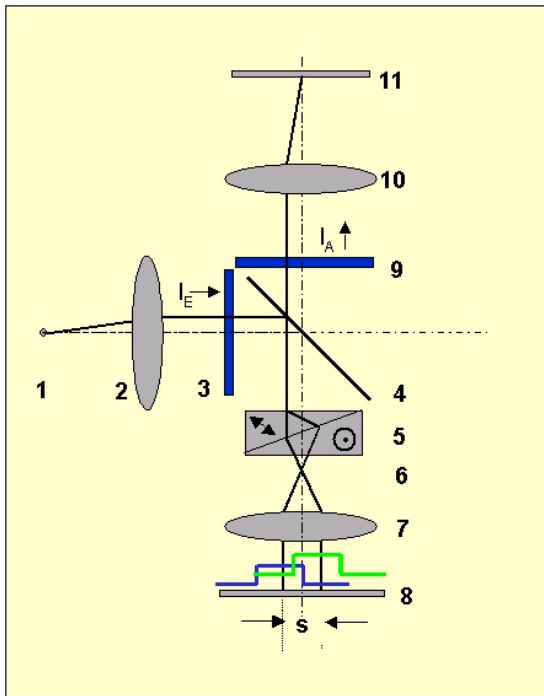
- [1] Nomarski, G., Interféromètre à polarisation, French Patent 1.059.123, 1952
- [2] Beyer-Riesenberg, Handbuch der Mikroskopie, VEB Verlag Technik Berlin, 1988
- [3] Danz, R. et al., Interferenzkontrastanordnung, Patent Specification DD 257 888, 1988
- [4] Menzel et al., Fourieroptik und Holografie, Springer, Vienna/New York 1973

#### Contacts:

Rainer Danz  
 Carl Zeiss  
 Lichtmikroskopie / Light microscopy  
 Königsallee 9-21  
 D-37081 Göttingen  
 Tel. +49 (0)551/5060-368  
 Fax +49 (0)551/5060-464  
 E-mail: [danz@zeiss.de](mailto:danz@zeiss.de)  
 Internet: [www.zeiss.de](http://www.zeiss.de)

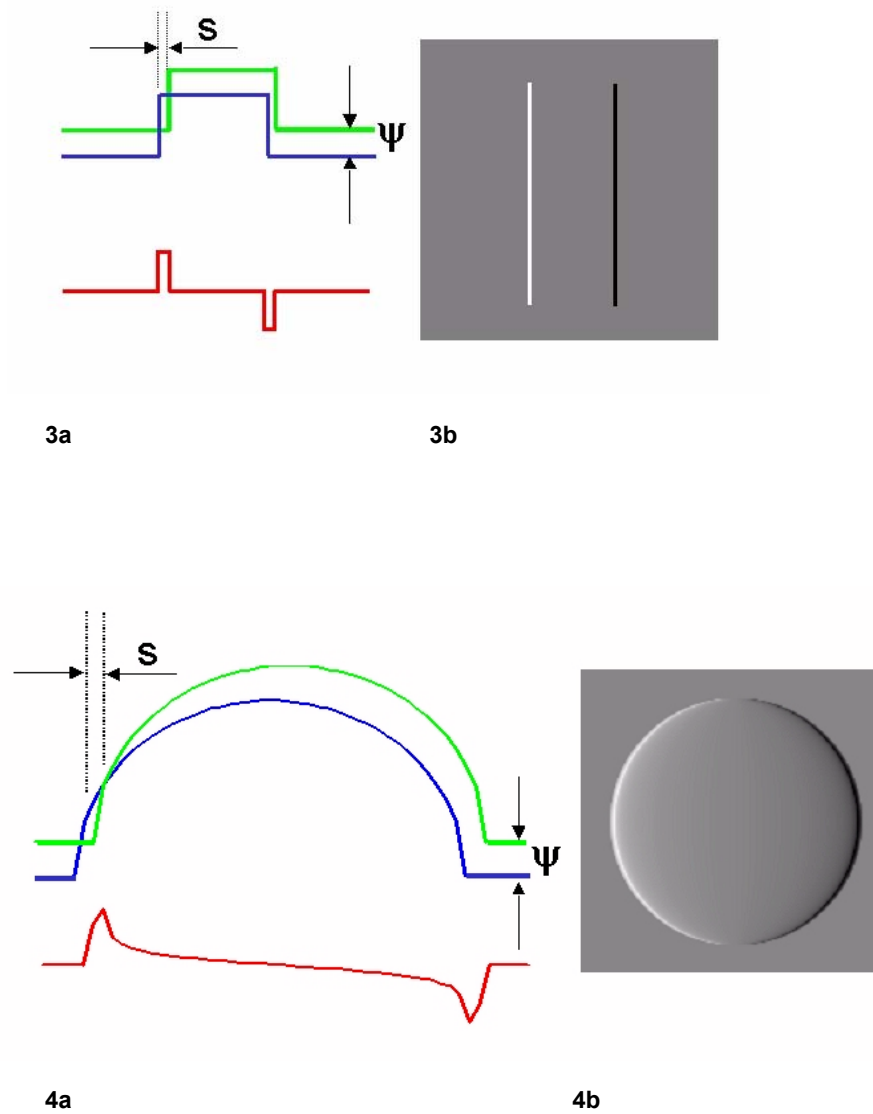


**Figure 1:** Geometric (left) and physical (right) incident light phase object: a geometric phase object superimposes the phase difference  $\Phi$  on the reflected light wave front. This phase difference is only dependent on the step height  $d$ . If the phase object demonstrates no differences in height but different materials, the light wave front is deformed by the difference in the material-specific phase shifts  $\gamma_1$  and  $\gamma_2$ .

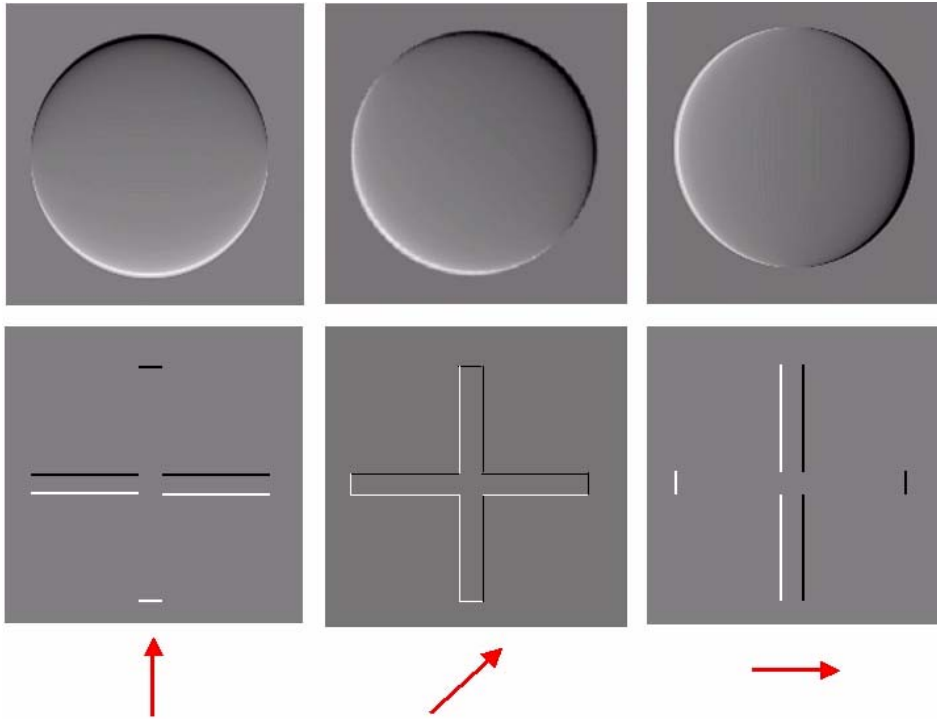


**Figure 2:** Optical diagram of differential interference contrast (DIC) according to Nomarski: 1 light source, 2 collector,  $I_E$  input intensity, 3 polarizer, 4 flat glass, 5 DIC prism (modified Wollaston prism<sup>1</sup>), 6 objective exit pupil, 7 objective, “blue” and “green”: image and twin image of the reflected wave front and the wave front deformed by the object, 8 specimen, 9 analyzer,  $I_A$  output intensity, 10 tube lens, 11 intermediate image plane

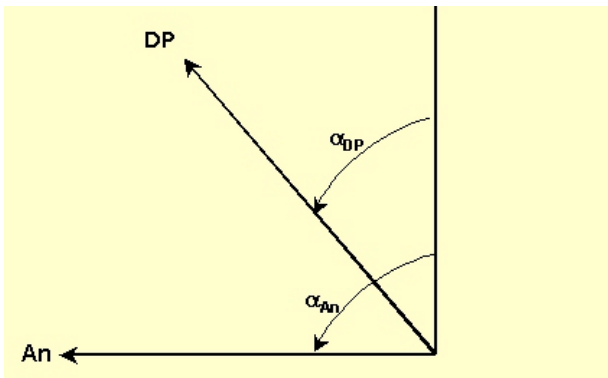
<sup>1</sup>In the modification according to Nomarski (1952) the crystallographic axis of one sub-prism does not lie parallel to the surface. This means that the ordinary and extraordinary beams are reunited (interference plane) not at the interface between the individual prisms (DIC concept according to Smith, 1947) but outside the Wollaston prism, and may coincide with the objective exit pupil, which generally lies inside the lens system. This means that special objectives with an integrated Wollaston prism are no longer needed to perform the DIC method; furthermore, the interference contrast can be varied ( $\psi$ -variation) simply by moving the prism perpendicular to the optical axis.



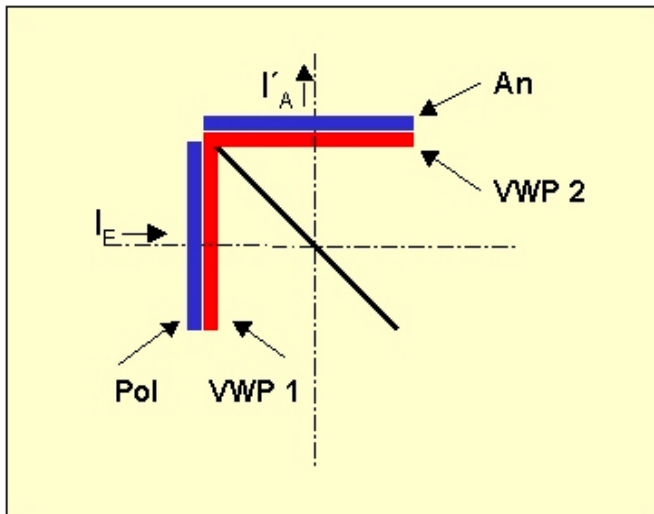
**Figure 3 and Figure 4:** a) The resulting phase differences (red) represent the first derivation of the two identical light wave fronts displaced laterally by the amount  $s$  (green and blue). b) The microscopic image gives the impression of a relief, although it is not directly possible to infer whether the object is raised or depressed (model of the gradient object in Figure 3b: Dr. Jan Thirase, Göttingen).



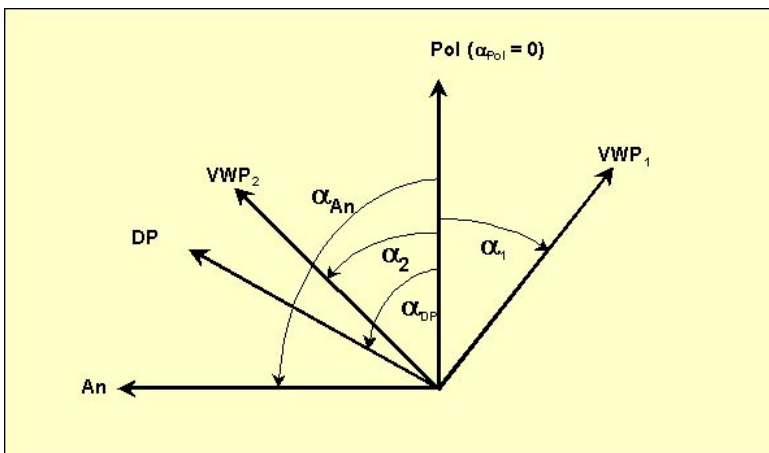
**Figure 5:** Top row: circular phase objects can be depicted in high contrast whatever the direction of the split (red arrows) of the DIC prism. Bottom row: on the other hand, straight structures show a significant azimuth effect that leads to misinterpretations.



**Figure 6:** Conventional arrangement of the DIC prism (DP), in which it must always be arranged diagonally to the polarizer and analyzer so that the interfering waves of ordinary and extraordinary light have equal amplitudes. If this is not the case, the interference contrast is reduced or totally disappears.



**Figure 7:** The generation of circular polarized light: the incident light of input intensity  $I_E$  is polarized linearly by the polarizer (Pol) and, after passing through the first quarter-wave plate (VWP1), converted into circular polarized light. Once the light has gone through the DIC prism for the first time, reflected on the phase object and gone through the DIC prism for the second time, it passes through the second quarter-wave plate (VWP2), which polarizes it linearly again. The output intensity  $I'_A$  is independent of the oscillation azimuth of the DIC prism because of the circular polarized light.

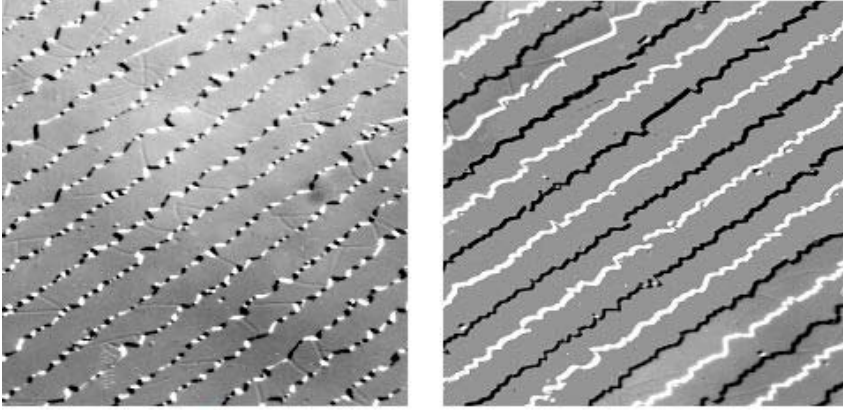


**Figure 8:** Diagram illustrating the C-DIC arrangement: unlike in conventional DIC, two further polarization-optical elements, namely the quarter-wave plates VWP1 and VWP2, have been added. Their azimuths  $\alpha_1$  and  $\alpha_2$  are crossed and lie diagonal to the polarizer and analyzer.

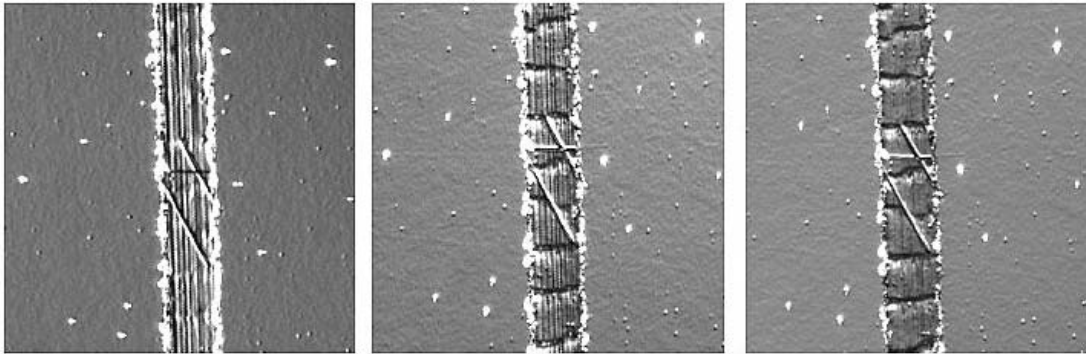


**Figure 9a:** C-DIC prism slider: the C-DIC prism can be rotated azimuthally using the large knurled ring; the image contrast is varied using the knurled adjusting screw (change to the phase difference  $\psi$ , see text).

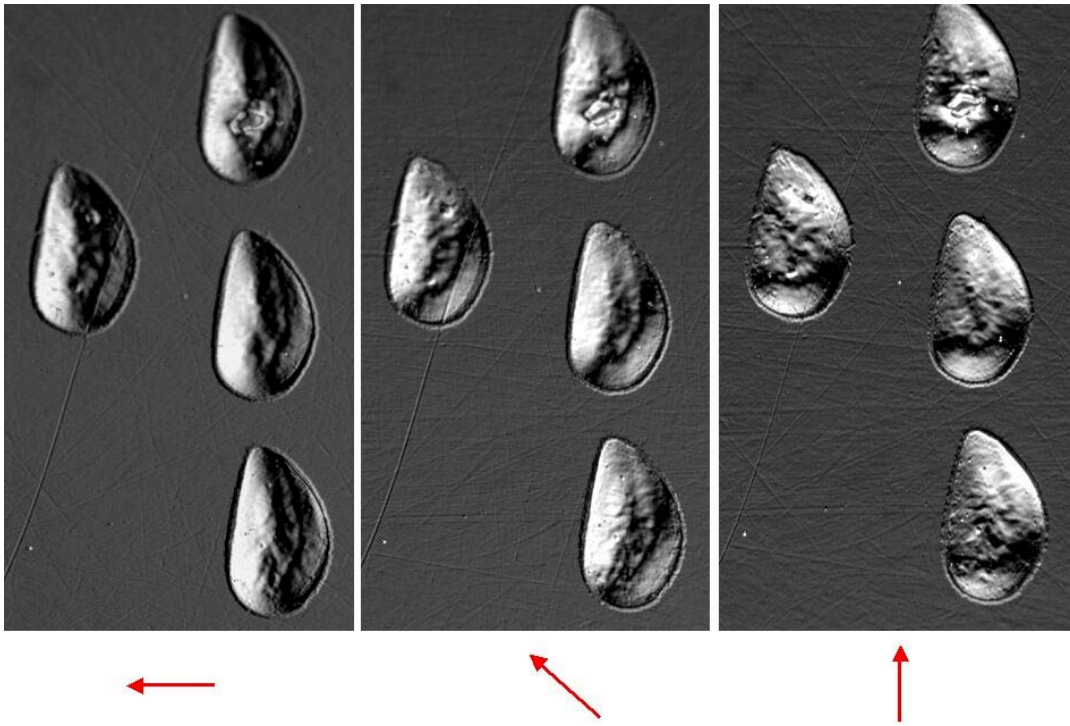
**Figure 9b:** On both the light entrance and the light exit sides the C-DIC reflector consists of a polar/quarter-wave plate combination arranged crosswise.



**Figure 10:** Images of the same phase object in which the directions of the split are perpendicular to each other. The difference in information is obvious (objective: EC Epiplan-Neofluar 10x/0.25.)



**Figure 11:** Synthetically manufactured phase object containing perpendicular phase structures. The red arrows indicate the direction of the split (objective: EC Epiplan-Neofluar 20x/0.50.)



**Figure 12:** Excimer laser ablation: signature mark on an optical surface (sample was kindly provided by Mr. A. Hanßen, Aalen; objective: EC Epiplan-Neofluar 20x/0.50.)